



AV681TX 5.8GHZ A/V TRANSMITTER KIT Rev-D Hardware

INTRODUCTION

This 5.8Ghz 100mW A/V transmitter kit provides a custom printed circuit board set and quality electronic components. All you need to add is an antenna of your choice and about three hours of your time.

NOTICE: This kit involves precision SMD soldering and it is NOT intended for beginners to assemble. It is suitable for amateur radio hobbyists and RF technicians. The builder must have good quality soldering tools, an anti-static work environment, and electronic assembly experience.

Note: This transmitter will require a ham radio license for hobby applications. Some countries may prohibit use. Please consult your government's spectrum regulations before using this device.



BILL OF MATERIALS

<u>QTY</u>	<u>DESCRIPTION</u>	<u>DESIGNATOR</u>	<u>NOTES</u>
3	.1uF Cap	C1, C3, C8	0805 pkg.
4	47uF 6V Cap	C6, C7, C20, C22	Observe polarity. 3528-21pkg.
1	47uF 16V Cap	C21	Observe polarity. 6032-28 pkg.
2	330uF Cap	C2, C4	Observe polarity. 7343-31 pkg.
3	2.2K Resistor	R1, R2, R3	0805 pkg.
1	22uH Inductor	L1	3225 pkg.
1	DL4001 Diode	D20	Observe polarity. MELF pkg.
2	KF50BDT	U20, U21	TO-252 pkg.
1	DIP Switch	S1	SOIC Package
1	SMA-RP Connector	N/A	Antenna connector
1	Tall Post Header, 4-pin	PCB Assy	Cut into one 2-pin and two 1-pin
1.75"	Heatshrink, 2" Size	N/A	See text
1	Double-sided foam pad	N/A	See text
1	AWM681TX or AWM683TX	RF Module	Airwave Module, 5.8GHz 100mW
1	Printed Circuit Board Set	PCB, Rev-D	2-piece PCB set

The following accessories are available separately. You may use our recommendations or any suitable equivalent:

AVAILABLE ACCESSORIES

- 5.8GHz 8dBi Patch Antenna, #HG5808P-SMA and Coax Cable #CSR400, #CSR402, or #CSR316.
- 5.8GHz 5dBi Patch Antenna, #AWM5.8ANT
- 5.8GHz 4dBi Dipole Antenna, #ANTDRP-5.8.
- 5.8GHz 2dBi Dipole Antenna, #ANTTRP-5.8.
- Tiny-Mic Amplified Microphone, #MIC-001

ASSEMBLY INSTRUCTIONS

1 GENERAL NOTES

- 1.1 These instructions are for the Rev-C hardware release. Before starting, be sure to confirm your kit is identified as Rev-C.
- 1.2 The top and bottom sides of the two PCB's are labeled with a circled number (e.g., ① ② ③ ④). The instructions will reference the numbered side that is being assembled.

2 SIDE ②, COMPONENTS: See Figure 2.

- 2.1 Install C20 and C22 (47uF/6V caps).
- 2.2 Install C21 (47uF/16V cap).
- 2.3 Install D20 (diode).
- 2.4 Install U20 and U21 (Vreg IC).

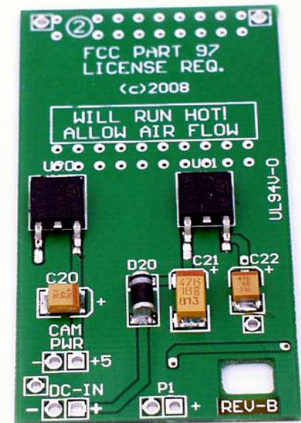

Figure 2, Side ②

3 SIDE ③, COMPONENTS: See Figure 3.

- 3.1 Install C1 and C3 (.1uF caps).
- 3.2 Install C6 and C7 (47uF/6V caps).
- 3.3 Install C2 and C4 (330uF caps).
- 3.4 Install L1 (inductor).
- 3.5 Install S1 (4-position switch). Orient it so that the "1234" text is at the front edge.

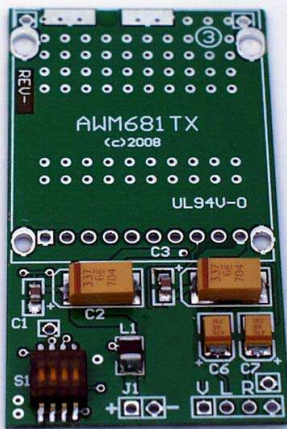
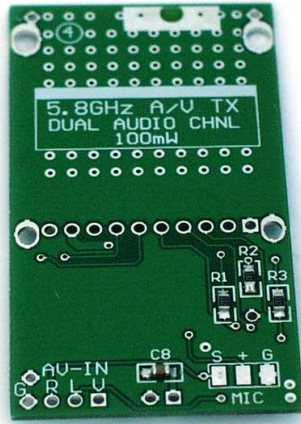

Figure 3, Side ③



4 SIDE ④, COMPONENTS: See Figure 4.

- 4.1 Install R1, R2, and R3 (2.2K resistors).
- 4.2 Install C8 (.1uF cap).

Figure 4, Side ④

5 SIDE ③, POST INSTALLATION: See Figure 5.

- 5.1 Carefully cut the standoff post header so that you have one piece that is 2-pins and two pieces that are 1-pin.
- 5.2 Install the 2-pin POWER post at J1.
- 5.3 Install a 1-pin GND post at the hole next to C1+ .
- 5.4 Install a 1-pin GND post at the hole next to C7+.

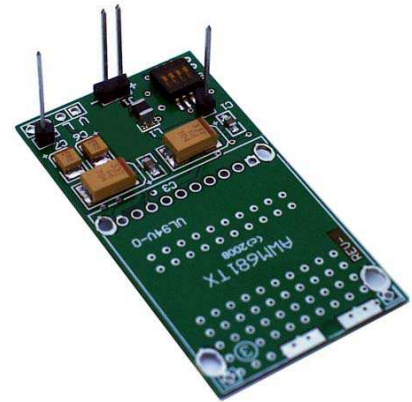

Figure 5, Stand-Off Posts

6 SIDE ②, POWER CABLE INSTALLATION AND VREG TEST.

- 6.1 Install your preferred DC power cable/connector (such as a female BEC) to the DC-IN pads. Be sure to observe the marked polarity. Label the cable "6.5-8.5VDC BAT-IN."
- 6.2 If you will be powering your 5VDC camera from the transmitter then install your camera's power cable to the CAM PWR pads (observe marked polarity). Label the cable "5VDC @150mA CAM-OUT."
- 6.3 Visually inspect side ② for assembly errors and solder issues. Correct all problems before proceeding.
- 6.4 Temporarily apply power (6.5VDC to 8.5VDC) to the DC-IN cable. Using a digital voltmeter, verify 5.0VDC ($\pm 0.15V$) at the P1 pads and the CAM-PWR cable.

7 RF MODULE INSTALLATION: See Figure 6.

Note: The RF Module and the SMA-RP installation have changed with the Rev-C release.

- 7.1 Place the RF module on the PCB (Side ③). It will have a gap between it and the PCB. It does NOT sit flush. See Figure 6 for details.

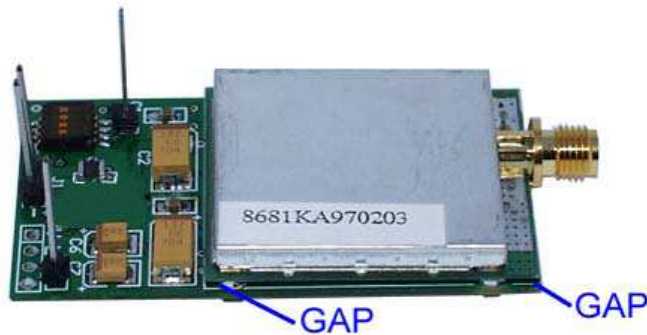

Figure 6, RF Module Installation

- 7.2 Before soldering the RF module in place, temporarily slide the SMA-RP connector onto the module's RF output. See Figure 7. Adjust the module's placement on the PCB until the center pin of the SMA-RP is centered on top of the module's RF output trace. Once positioned, solder the module's four corners and its ten pins. Do not solder the SMA-RP at this time.

8 SMA-RP INSTALLATION: See Figures 7 and 8.

- 8.1 Slide the SMA-RP connector onto the RF output. See Figure 7. Do not allow the connector's center pin to short to the module's metal case (allow 50 mils clearance).
- 8.2 While holding it straight and parallel with the PCB, carefully solder the SMA-RP center pin and all four ground legs (top and bottom). Clean off ALL flux, even if no-clean solder was used. Do a visual inspection for solder shorts (do not use an ohmmeter).

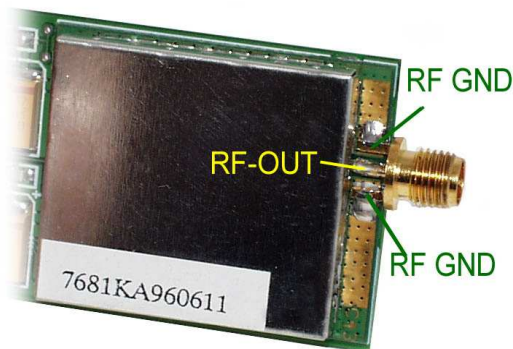

Figure 7, SMA-RP Top Side

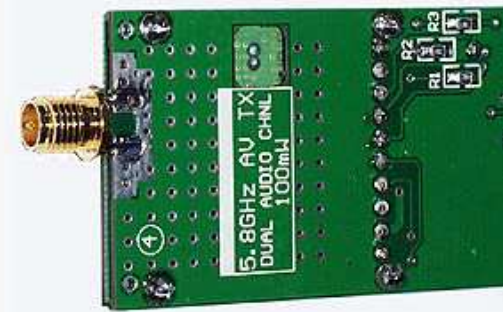

Figure 8, SMA-RP Bottom Side

- 8.3 If the RF module is expected to be used in an application that has vibration then it is helpful to solder two diagonal corners of the RF module's top tin lid to the tin metal base. This will help prevent video noise.

9 SIDE ④, A/V CABLE INSTALLATION: See Figure 9.

- 9.1 Install your audio/video wires to the AV-IN pads as follows:

G = A/V GND
R = RIGHT AUDIO
L = LEFT AUDIO
V = VIDEO

- 9.2 If a line-level microphone will be used (our Tiny-Mic is highly recommended) then install it at the MIC pads as follows:

Mic Audio = **S**
5V Power = **+**
Mic Gnd = **G**

Note: The MIC input feature uses the right audio channel. Do not use the right channel on the A/V-IN input if a Microphone is installed on the MIC input.

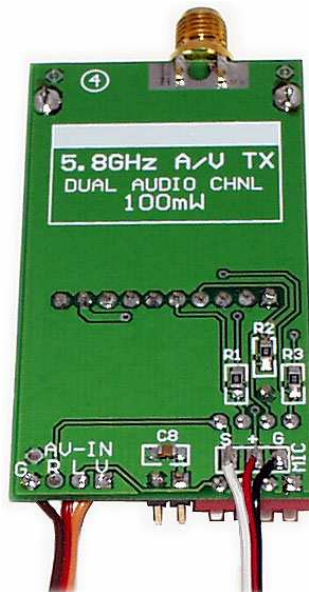

Figure 9, A/V Cables

10 FINAL ASSEMBLY: JOIN THE TWO PCB'S TOGETHER

- 10.1 Using an approved PCB cleaner, remove the flux from ALL soldered connections. Flush trim all the component leads from sides ① and ④.
- 10.2 Inspect your work. Now is the time to find errors -- once the boards are joined it will be very inconvenient to do this.
- 10.3 See Figure 10. Cut the double-sided foam pad in half. Stack the two pieces together to form a thicker pad. Install the pad on the RF end of the Airwave module.
- 10.4 Stack the two PCB's with sides ② and ③ facing each other. The four posts will mate with the corresponding holes on side ②.

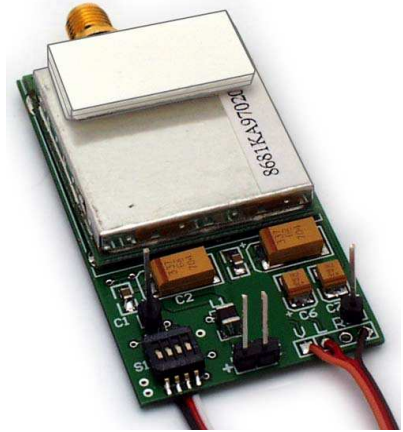

Figure 10, Foam Pad

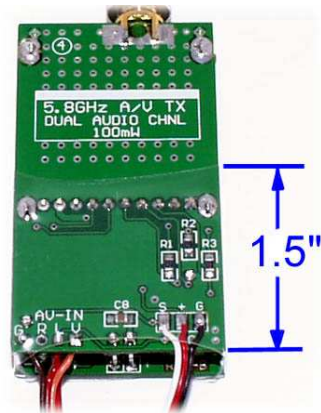

Figure 11, Heatshrink

- 10.5 While lightly squeezing the foam pad end, ensure that the two boards are parallel and close together. There should be a slight air space between the Vreg IC's and the top of the Airwave module. Hold this position while you solder the four posts. Trim the excess leads.
- 10.6 See Figure 11. Slide a 1.75 inches (45mm) long piece of heatshrink over the transmitter so that it covers the end with the exposed electronics. About 0.25 inches (6mm) should hang over the end that has all the wires. Airflow is needed so do NOT totally cover the end. Use a heat gun or hot hair dryer and neatly shrink the tubing. Matches and lighters are not recommended.

11 FREQUENCY CONFIGURATION

- 11.1 The DIP switch is used to change the transmitted frequency. The transmitter and receiver must both be on the same channel. The three switches are set as follows:

CH	MHz	SW1	SW2	SW3	
1	5740	ON	ON	ON	OFF = switch open (Front position)
2	5760	ON	ON	OFF	
3	5780	ON	OFF	ON	ON = switch closed (Back position)
4	5800	ON	OFF	OFF	
5	5820	OFF	ON	ON	
6	5840	OFF	ON	OFF	
7	5860	OFF	OFF	ON	

12 AUDIO CONFIGURATION

- 12.1 DIP Switch position four is used to control a special audio feature. When ON (SW-4 closed), it will bridge the left and right audio channels together. This is used to transmit mono sound with both channels. For independent audio channels you must turn it OFF (SW-4 open).

13 TECHNICAL INFORMATION

For complete technical information, please consult the AWM681TX or AWM683TX data sheet (available from dpcav.com's web site) and the attached schematic.

NOTICE

Digital Products Company, or their distributors, have no control over the assembly and use of this A/V RF system. As such, no liability may be assumed, nor will any liability be accepted, for any damages resulting from the use of this product. Under no circumstances will the buyer be entitled to consequential or incidental damages. By act of using it, the buyer accepts all resulting liability.

AV681TX 5.8GHZ TRANSMITTER

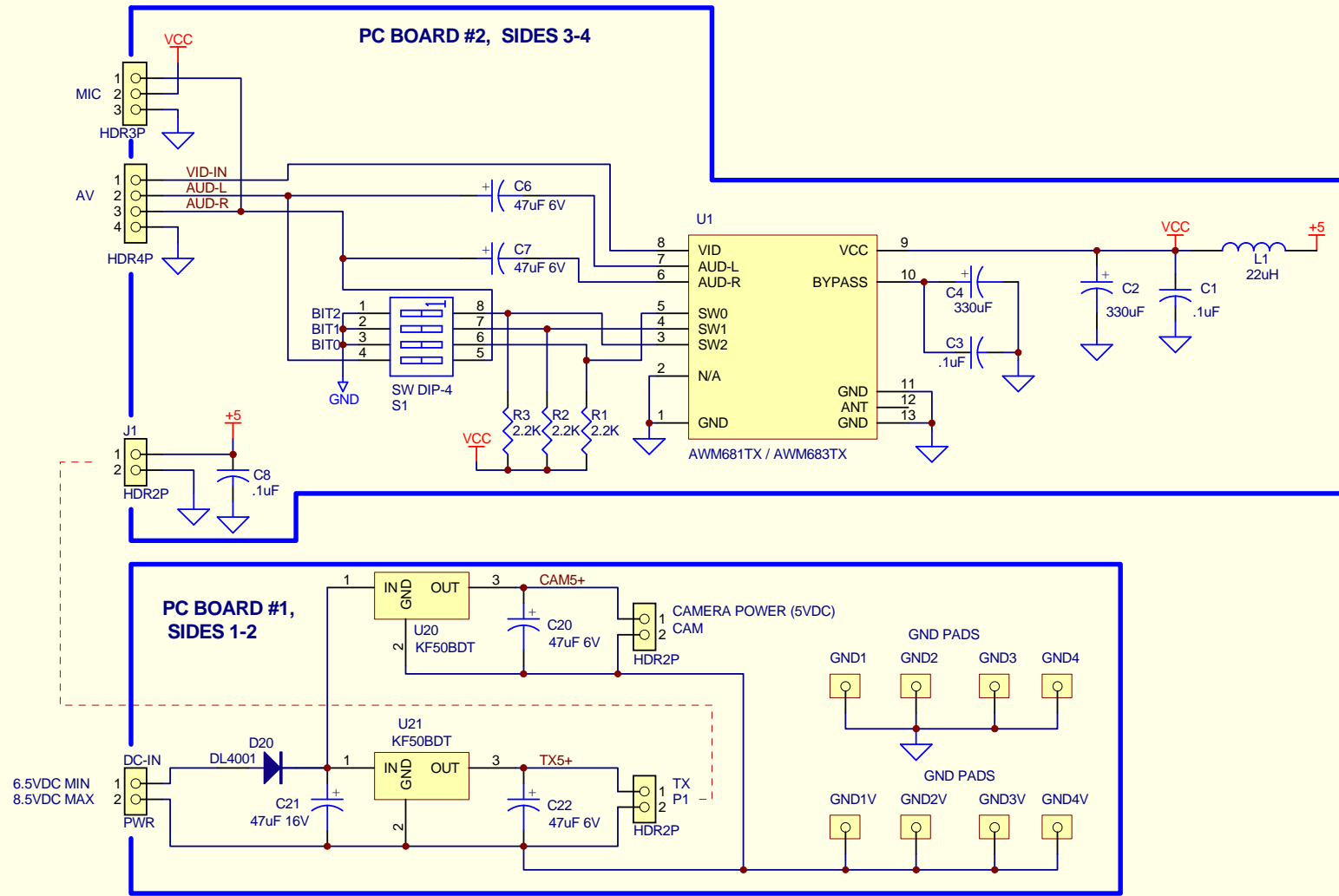

Title: 5.8GHz Wireless A/V Tx KIT		
Size: Letter	AV681TX	Revision: D
Date: FEB-07-2009	Sheet 1 of 1	
Copyright: 2008-2009		

www.dpcav.com

DPC A/V
AUDIO VIDEO